

Root bundles: Applications to F-theory Standard model

Martin Bies

RPTU Kaiserslautern-Landau

22nd String Pheno Conference

Daejeon, South Korea

July 6, 2023

Based on work with M. Cvetič, R. Donagi, M. Liu, M. Ong
2102.10115, 2104.08297, 2205.00008, 2303.08144 & 230x.xxx.

Desired vector-like spectra in the F-theory QSMs [Cvetič Halverson Lin Liu Tian '19]

Rep. \mathbf{R} of $SU(3) \times SU(2) \times U(1)$	$n_{\mathbf{R}} = \#$ chiral superfields in rep \mathbf{R}	$n_{\overline{\mathbf{R}}} = \#$ chiral superfields in rep $\overline{\mathbf{R}}$	Chiral index $\chi = n_{\mathbf{R}} - n_{\overline{\mathbf{R}}}$
$(\mathbf{3}, \mathbf{2})_{1/6}$			
$(\mathbf{1}, \mathbf{2})_{-1/2}$			
$(\overline{\mathbf{3}}, \mathbf{1})_{-2/3}$			
$(\overline{\mathbf{3}}, \mathbf{1})_{1/3}$			
$(\mathbf{1}, \mathbf{1})_1$			
How to compute?			

Desired vector-like spectra in the F-theory QSMs [Cvetič Halverson Lin Liu Tian '19]

Rep. \mathbf{R} of $SU(3) \times SU(2) \times U(1)$	$n_{\mathbf{R}} = \#$ chiral superfields in rep \mathbf{R}	$n_{\overline{\mathbf{R}}} = \#$ chiral superfields in rep $\overline{\mathbf{R}}$	Chiral index $\chi = n_{\mathbf{R}} - n_{\overline{\mathbf{R}}}$
$(\mathbf{3}, \mathbf{2})_{1/6}$			3
$(\mathbf{1}, \mathbf{2})_{-1/2}$			3
$(\overline{\mathbf{3}}, \mathbf{1})_{-2/3}$			3
$(\overline{\mathbf{3}}, \mathbf{1})_{1/3}$			3
$(\mathbf{1}, \mathbf{1})_1$			3
How to compute?			

Desired vector-like spectra in the F-theory QSMs [Cvetič Halverson Lin Liu Tian '19]

Rep. \mathbf{R} of $SU(3) \times SU(2) \times U(1)$	$n_{\mathbf{R}} = \#$ chiral superfields in rep \mathbf{R}	$n_{\overline{\mathbf{R}}} = \#$ chiral superfields in rep $\overline{\mathbf{R}}$	Chiral index $\chi = n_{\mathbf{R}} - n_{\overline{\mathbf{R}}}$
$(\mathbf{3}, \mathbf{2})_{1/6}$	3	0	3
$(\mathbf{1}, \mathbf{2})_{-1/2}$	4	1	3
$(\overline{\mathbf{3}}, \mathbf{1})_{-2/3}$	3	0	3
$(\overline{\mathbf{3}}, \mathbf{1})_{1/3}$	3	0	3
$(\mathbf{1}, \mathbf{1})_1$	3	0	3
How to compute?			

Desired vector-like spectra in the F-theory QSMs [Cvetič Halverson Lin Liu Tian '19]

Rep. \mathbf{R} of $SU(3) \times SU(2) \times U(1)$	$n_{\mathbf{R}} = \#$ chiral superfields in rep \mathbf{R}	$n_{\overline{\mathbf{R}}} = \#$ chiral superfields in rep $\overline{\mathbf{R}}$	Chiral index $\chi = n_{\mathbf{R}} - n_{\overline{\mathbf{R}}}$
$(\mathbf{3}, \mathbf{2})_{1/6}$	3	0	3
$(\mathbf{1}, \mathbf{2})_{-1/2}$	4 <small>$(4, 1) = (3, 0) \oplus (\mathbf{1}, \mathbf{1}) = \text{leptons} + \text{Higgs}$</small>	1	3
$(\overline{\mathbf{3}}, \mathbf{1})_{-2/3}$	3	0	3
$(\overline{\mathbf{3}}, \mathbf{1})_{1/3}$	3	0	3
$(\mathbf{1}, \mathbf{1})_1$	3	0	3
How to compute?			

Desired vector-like spectra in the F-theory QSMs [Cvetič Halverson Lin Liu Tian '19]

Rep. \mathbf{R} of $SU(3) \times SU(2) \times U(1)$	$n_{\mathbf{R}} = \#$ chiral superfields in rep \mathbf{R}	$n_{\overline{\mathbf{R}}} = \#$ chiral superfields in rep $\overline{\mathbf{R}}$	Chiral index $\chi = n_{\mathbf{R}} - n_{\overline{\mathbf{R}}}$
$(\mathbf{3}, \mathbf{2})_{1/6}$	3	0	3
$(\mathbf{1}, \mathbf{2})_{-1/2}$	4 <small>$(4, 1) = (3, 0) \oplus (\mathbf{1}, \mathbf{1}) = \text{leptons} + \text{Higgs}$</small>	1	3
$(\overline{\mathbf{3}}, \mathbf{1})_{-2/3}$	3	0	3
$(\overline{\mathbf{3}}, \mathbf{1})_{1/3}$	3	0	3
$(\mathbf{1}, \mathbf{1})_1$	3	0	3
How to compute?			$\chi = \int_{S_{\mathbf{R}}} G_4 = 3$ <p>[Cvetič Halverson Lin Liu Tian '19]</p>

Desired vector-like spectra in the F-theory QSMs [Cvetič Halverson Lin Liu Tian '19]

Rep. \mathbf{R} of $SU(3) \times SU(2) \times U(1)$	$n_{\mathbf{R}} = \#$ chiral superfields in rep \mathbf{R}	$n_{\overline{\mathbf{R}}} = \#$ chiral superfields in rep $\overline{\mathbf{R}}$	Chiral index $\chi = n_{\mathbf{R}} - n_{\overline{\mathbf{R}}}$
$(\mathbf{3}, \mathbf{2})_{1/6}$	3	0	3
$(\mathbf{1}, \mathbf{2})_{-1/2}$	4 <small>$(4, 1) = (3, 0) \oplus (\mathbf{1}, \mathbf{1}) = \text{leptons} + \text{Higgs}$</small>	1	3
$(\overline{\mathbf{3}}, \mathbf{1})_{-2/3}$	3	0	3
$(\overline{\mathbf{3}}, \mathbf{1})_{1/3}$	3	0	3
$(\mathbf{1}, \mathbf{1})_1$	3	0	3
How to compute?	$h^0(C_{\mathbf{R}}, \mathcal{L}_{\mathbf{R}})$ <small>[M.B. Mayrhofer Pehle Weigand '14], [M.B. Mayrhofer Weigand '17]</small> <small>[M.B. '18] and references therein</small>	$h^1(C_{\mathbf{R}}, \mathcal{L}_{\mathbf{R}})$	$\chi = \int_{S_{\mathbf{R}}} G_4 = 3$ <small>[Cvetič Halverson Lin Liu Tian '19]</small>

Desired vector-like spectra in the F-theory QSMs [Cvetič Halverson Lin Liu Tian '19]

Rep. \mathbf{R} of $SU(3) \times SU(2) \times U(1)$	$n_{\mathbf{R}} = \#$ chiral superfields in rep \mathbf{R}	$n_{\overline{\mathbf{R}}} = \#$ chiral superfields in rep $\overline{\mathbf{R}}$	Chiral index $\chi = n_{\mathbf{R}} - n_{\overline{\mathbf{R}}}$
$(\mathbf{3}, \mathbf{2})_{1/6}$	3	0	3
$(\mathbf{1}, \mathbf{2})_{-1/2}$	4 <small>$(4, 1) = (3, 0) \oplus (\mathbf{1}, \mathbf{1}) = \text{leptons} + \text{Higgs}$</small>	1	3
$(\overline{\mathbf{3}}, \mathbf{1})_{-2/3}$	3	0	3
$(\overline{\mathbf{3}}, \mathbf{1})_{1/3}$	3	0	3
$(\mathbf{1}, \mathbf{1})_1$	3	0	3
How to compute?	$h^0(C_{\mathbf{R}}, \mathcal{L}_{\mathbf{R}})$ <small>[M.B. Mayrhofer Pehle Weigand '14], [M.B. Mayrhofer Weigand '17]</small> <small>[M.B. '18] and references therein</small>	$h^1(C_{\mathbf{R}}, \mathcal{L}_{\mathbf{R}})$	$\chi = \deg(\mathcal{L}_{\mathbf{R}}) - g(C_{\mathbf{R}}) + 1$ $\chi = \int_{S_{\mathbf{R}}} G_4 = 3$ <small>[Cvetič Halverson Lin Liu Tian '19]</small>

General findings

- Matter in rep. \mathbf{R} localized on smooth, irreducible matter curve $C_{\mathbf{R}}$ of genus g .
 - It holds $\mathcal{L}_{\mathbf{R}} = \mathcal{S} \otimes \mathcal{F}_{\mathbf{R}}$ [M.B. Mayrhofer Pehle Weigand '14], [M.B. Mayrhofer Weigand '17], [M.B. '18]
 - \mathcal{S} is one of the 2^{2g} spin bundles on $C_{\mathbf{R}}$. [Atiyah '71], [Mumford '71]
 - $\mathcal{F}_{\mathbf{R}}$ a contribution from the G_4 -flux.
- \Rightarrow Compute $n_{\mathbf{R}} = h^0(C_{\mathbf{R}}, \mathcal{L}_{\mathbf{R}})$ and $n_{\overline{\mathbf{R}}} = h^1(C_{\mathbf{R}}, \mathcal{L}_{\mathbf{R}})$.

Challenges for vector-like spectra in F-theory QSMs

General findings

- Matter in rep. \mathbf{R} localized on smooth, irreducible matter curve $C_{\mathbf{R}}$ of genus g .
 - It holds $\mathcal{L}_{\mathbf{R}} = \mathcal{S} \otimes \mathcal{F}_{\mathbf{R}}$ [M.B. Mayrhofer Pehle Weigand '14], [M.B. Mayrhofer Weigand '17], [M.B. '18]
 - \mathcal{S} is one of the 2^{2g} spin bundles on $C_{\mathbf{R}}$. [Atiyah '71], [Mumford '71]
 - $\mathcal{F}_{\mathbf{R}}$ a contribution from the G_4 -flux.
- ⇒ Compute $n_{\mathbf{R}} = h^0(C_{\mathbf{R}}, \mathcal{L}_{\mathbf{R}})$ and $n_{\overline{\mathbf{R}}} = h^1(C_{\mathbf{R}}, \mathcal{L}_{\mathbf{R}})$.

Challenges

- $n_{\mathbf{R}}, n_{\overline{\mathbf{R}}}$ depend on choice of spin bundle. Which \mathcal{S} is compatible with the physics?
- In QSMs, cannot (yet) find unique $\mathcal{F}_{\mathbf{R}}$. [M.B. Cvetič Donagi Liu Ong '21]
- Both points fairly tricky to address.
 - Instead, formulate **necessary** conditions and study their solutions.

For $(3, 2)_{1/6}$, find **necessary** condition: $\mathcal{L}_{(3,2)_{1/6}} = \sqrt[20]{K_{\mathcal{C}_{(3,2)_{1/6}}}^{\otimes 16}}$

(Constraint stated for base 3-folds B_3 with $K_{B_3}^3 = 10$. See [M.B. Cvetič Donagi Liu Ong '21] for constraints in bases B_3 with other $K_{B_3}^3$.)

- Has 20^{12} solutions \leftrightarrow Infinitely many line bundles with $\chi = 3$.
→ **Highly non-trivial** constraint.
 - Likely, not all solutions physical (\leftrightarrow **necessary** condition).
→ To be addressed in future work.
- ⇒ Goal: Compute $h^0(\mathcal{C}_{(3,2)_{1/6}}, \mathcal{L}_{(3,2)_{1/6}})$ for all 20^{12} solutions.

For $(3, 2)_{1/6}$, find **necessary** condition: $\mathcal{L}_{(3,2)_{1/6}} = \sqrt[20]{K_{\mathcal{C}_{(3,2)_{1/6}}}^{\otimes 16}}$

(Constraint stated for base 3-folds B_3 with $K_{B_3}^3 = 10$. See [M.B. Cvetič Donagi Liu Ong '21] for constraints in bases B_3 with other $K_{B_3}^3$.)

- Has 20^{12} solutions \leftrightarrow Infinitely many line bundles with $\chi = 3$.
→ **Highly non-trivial** constraint.
 - Likely, not all solutions physical (\leftrightarrow **necessary** condition).
→ To be addressed in future work.
- ⇒ Goal: Compute $h^0(\mathcal{C}_{(3,2)_{1/6}}, \mathcal{L}_{(3,2)_{1/6}})$ for all 20^{12} solutions.

Challenges

- Hard to construct solutions $\mathcal{L}_{(3,2)_{1/6}}$ on **smooth, irreducible** curve.
- $h^0(\mathcal{C}_{(3,2)_{1/6}}, \mathcal{L}_{(3,2)_{1/6}})$ may depend on complex structure.

- F-theory QSMs admit **canonical nodal** matter curve C_R^\bullet [M.B. Cvetič Liu '21]

(Nodal curve: At most finitely many nodal singularities, which in turn locally look like $x \cdot y = 0$.)

- F-theory QSMs admit **canonical nodal** matter curve \mathcal{C}_R^\bullet [M.B. Cvetič Liu '21]

(Nodal curve: At most finitely many nodal singularities, which in turn locally look like $x \cdot y = 0$.)

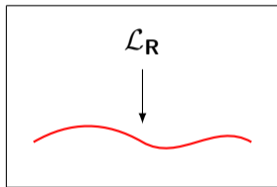

- F-theory QSMs admit **canonical nodal** matter curve \mathcal{C}_R^\bullet [M.B. Cvetič Liu '21]

(Nodal curve: At most finitely many nodal singularities, which in turn locally look like $x \cdot y = 0$.)

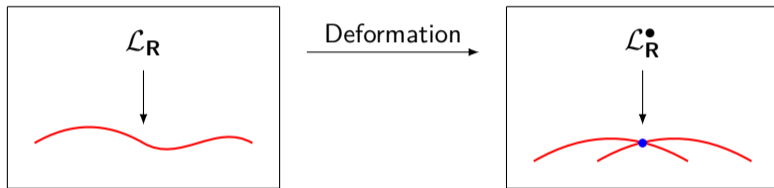

- F-theory QSMs admit **canonical nodal** matter curve C_R^\bullet [M.B. Cvetič Liu '21]

(Nodal curve: At most finitely many nodal singularities, which in turn locally look like $x \cdot y = 0$.)

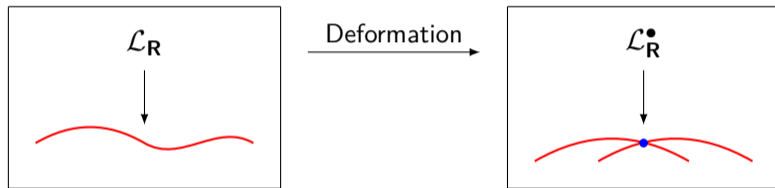

- Limit root bundles on C_R^\bullet well understood [Jarves '98], [Caporaso Casagrande Cornalba '04].

- F-theory QSMs admit **canonical nodal** matter curve C_R^\bullet [M.B. Cvetič Liu '21]

(Nodal curve: At most finitely many nodal singularities, which in turn locally look like $x \cdot y = 0$.)

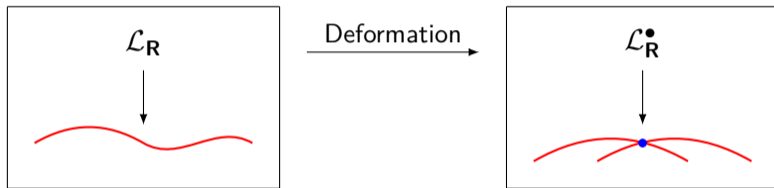

- Limit root bundles on C_R^\bullet well understood [Jarves '98], [Caporaso Casagrande Cornalba '04].
 - Explicit description from bi-weighted graphs.
 - Enumeration of **all** limit roots is combinatoric challenge (\leftrightarrow computer program).

- F-theory QSMs admit **canonical nodal** matter curve C_R^\bullet [M.B. Cvetič Liu '21]

(Nodal curve: At most finitely many nodal singularities, which in turn locally look like $x \cdot y = 0$.)

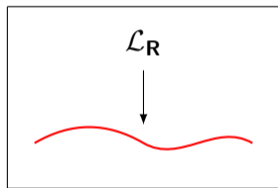

Deformation \rightarrow

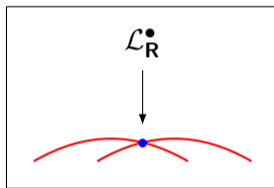

Enumerate all limit roots with computer and **try to find** h^0 .

(<https://github.com/Julia-meets-String-Theory/RootCounter>)

- Limit root bundles on C_R^\bullet well understood [Jarves '98], [Caporaso Casagrande Cornalba '04].
 - Explicit description from bi-weighted graphs.
 - Enumeration of **all** limit roots is combinatoric challenge (\leftrightarrow computer program).

- F-theory QSMs admit **canonical nodal** matter curve C_R^\bullet [M.B. Cvetič Liu '21]

(Nodal curve: At most finitely many nodal singularities, which in turn locally look like $x \cdot y = 0$.)

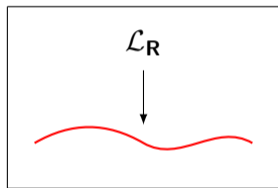

Deformation \longrightarrow

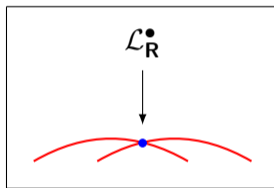

Enumerate all limit roots with computer and **try to find** h^0 .

(<https://github.com/Julia-meets-String-Theory/RootCounter>)

- Limit root bundles on C_R^\bullet well understood [Jarves '98], [Caporaso Casagrande Cornalba '04].
 - Explicit description from bi-weighted graphs.
 - Enumeration of **all** limit roots is combinatoric challenge (\leftrightarrow computer program).
 - Upper semicontinuity: $h^0(C_R, \mathcal{L}_R) \leq h^0(C_R^\bullet, \mathcal{L}_R^\bullet)$.

- F-theory QSMs admit **canonical nodal** matter curve C_R^\bullet [M.B. Cvetič Liu '21]

(Nodal curve: At most finitely many nodal singularities, which in turn locally look like $x \cdot y = 0$.)

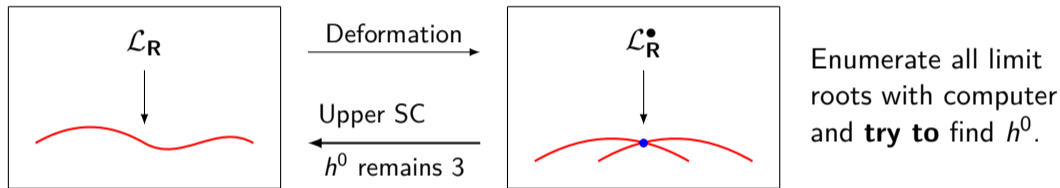

(<https://github.com/Julia-meets-String-Theory/RootCounter>)

- Limit root bundles on C_R^\bullet well understood [Jarves '98], [Caporaso Casagrande Cornalba '04].
 - Explicit description from bi-weighted graphs.
 - Enumeration of **all** limit roots is combinatoric challenge (\leftrightarrow computer program).
 - Upper semicontinuity: $h^0(C_R, \mathcal{L}_R) \leq h^0(C_R^\bullet, \mathcal{L}_R^\bullet)$.

Brill-Noether numbers of $(\overline{3}, 2)_{1/6}$ in QSMs [M.B. Cvetič Liu '21]

QSM-family (polytope)	$h^0 = 3$	$h^0 \geq 3$	$h^0 = 4$	$h^0 \geq 4$	$h^0 = 5$	$h^0 \geq 5$	$h^0 = 6$	$h^0 \geq 6$
Δ_8°	57.3	?	?	?	?	?	?	?

Brill-Noether numbers of $(\mathbf{3}, \mathbf{2})_{1/6}$ in QSMs [M.B. Cvetič Liu '21]

QSM-family (polytope)	$h^0 = 3$	$h^0 \geq 3$	$h^0 = 4$	$h^0 \geq 4$	$h^0 = 5$	$h^0 \geq 5$	$h^0 = 6$	$h^0 \geq 6$
Δ_8°	57.3	?	?	?	?	?	?	?
Δ_4°	53.6	?	?	?	?	?	?	?
Δ_{134}°	48.7	?	?	?	?	?	?	?
$\Delta_{128}^\circ, \Delta_{130}^\circ, \Delta_{136}^\circ, \Delta_{236}^\circ$	42.0	?	?	?	?	?	?	?
Δ_{88}°	61.1	?	?	?	?	?	?	?
Δ_{110}°	57.8	?	?	?	?	?	?	?
$\Delta_{272}^\circ, \Delta_{274}^\circ$	57.5	?	?	?	?	?	?	?
Δ_{387}°	57.3	?	?	?	?	?	?	?
$\Delta_{798}^\circ, \Delta_{808}^\circ, \Delta_{810}^\circ, \Delta_{812}^\circ$	54.0	?	?	?	?	?	?	?
Δ_{254}°	54.7	?	?	?	?	?	?	?
Δ_{52}°	54.7	?	?	?	?	?	?	?
Δ_{302}°	54.7	?	?	?	?	?	?	?
Δ_{786}°	51.3	?	?	?	?	?	?	?
Δ_{762}°	51.3	?	?	?	?	?	?	?
Δ_{417}°	51.3	?	?	?	?	?	?	?
Δ_{838}°	51.3	?	?	?	?	?	?	?
Δ_{782}°	51.3	?	?	?	?	?	?	?
$\Delta_{377}^\circ, \Delta_{499}^\circ, \Delta_{503}^\circ$	48.2	?	?	?	?	?	?	?
Δ_{1348}°	48.2	?	?	?	?	?	?	?
$\Delta_{882}^\circ, \Delta_{856}^\circ$	48.2	?	?	?	?	?	?	?
Δ_{1340}°	45.2	?	?	?	?	?	?	?
Δ_{1879}°	45.2	?	?	?	?	?	?	?
Δ_{1384}°	42.5	?	?	?	?	?	?	?

Brill-Noether numbers of $(\mathbf{3}, \mathbf{2})_{1/6}$ in QSMs [M.B. Cvetič Donagi Ong '22]

QSM-family (polytope)	$h^0 = 3$	$h^0 \geq 3$	$h^0 = 4$	$h^0 \geq 4$	$h^0 = 5$	$h^0 \geq 5$	$h^0 = 6$	$h^0 \geq 6$
Δ_8°	76.4	23.6						
Δ_4°	99.0	1.0						
Δ_{134}°	99.8	0.2						
$\Delta_{128}^\circ, \Delta_{130}^\circ, \Delta_{136}^\circ, \Delta_{236}^\circ$	99.9	0.1						
Δ_{88}°	74.9	22.1	2.5	0.5	0.0	0.0		
Δ_{110}°	82.4	14.1	3.1	0.4	0.0			
$\Delta_{272}^\circ, \Delta_{274}^\circ$	78.1	18.0	3.4	0.5	0.0	0.0		
Δ_{387}°	73.8	21.9	3.5	0.7	0.0	0.0		
$\Delta_{798}^\circ, \Delta_{808}^\circ, \Delta_{810}^\circ, \Delta_{812}^\circ$	77.0	17.9	4.4	0.7	0.0	0.0		
Δ_{254}°	95.9	0.5	3.5	0.0	0.0	0.0		
Δ_{52}°	95.3	0.7	3.9	0.0	0.0	0.0		
Δ_{302}°	95.9	0.5	3.5	0.0	0.0			
Δ_{786}°	94.8	0.3	4.8	0.0	0.0	0.0		
Δ_{762}°	94.8	0.3	4.9	0.0	0.0	0.0		
Δ_{417}°	94.8	0.3	4.8	0.0	0.0	0.0	0.0	
Δ_{838}°	94.7	0.3	5.0	0.0	0.0	0.0		
Δ_{782}°	94.6	0.3	5.0	0.0	0.0	0.0		
$\Delta_{377}^\circ, \Delta_{499}^\circ, \Delta_{503}^\circ$	93.4	0.2	6.2	0.0	0.1	0.0		
Δ_{1348}°	93.7	0.0	6.2	0.0	0.1		0.0	
$\Delta_{882}^\circ, \Delta_{856}^\circ$	93.4	0.3	6.2	0.0	0.1	0.0	0.0	
Δ_{1340}°	92.3	0.0	7.6	0.0	0.1		0.0	
Δ_{1879}°	92.3	0.0	7.5	0.0	0.1		0.0	
Δ_{1384}°	90.9	0.0	8.9	0.0	0.2		0.0	

Brill-Noether numbers of $(\overline{3}, 2)_{1/6}$ in QSMs [M.B. Cvetič Donagi Ong – WIP]

QSM-family (polytope)	$h^0 = 3$	$h^0 \geq 3$	$h^0 = 4$	$h^0 \geq 4$	$h^0 = 5$	$h^0 \geq 5$	$h^0 = 6$	$h^0 \geq 6$
Δ_8°	99.9421		0.0579					
Δ_4°	99.9952		0.0048					
Δ_{134}°	99.9952		0.0048					
$\Delta_{128}^\circ, \Delta_{130}^\circ, \Delta_{136}^\circ, \Delta_{236}^\circ$	99.9952		0.0048					
Δ_{88}°	96.6700	0.3361	2.9850		0.0089			
Δ_{110}°	95.6268	0.8372	3.5179	0.0050	0.0131			
$\Delta_{272}^\circ, \Delta_{274}^\circ$	95.5097	0.5155	3.9552	0.0016	0.0180			
Δ_{387}°	95.1923	0.4981	4.2773		0.0323			
$\Delta_{798}^\circ, \Delta_{808}^\circ, \Delta_{810}^\circ, \Delta_{812}^\circ$	93.8268	0.8795	5.2390	0.0029	0.0518			
Δ_{254}°	96.3942	0.0687	3.5193	0.0003	0.0175			
Δ_{52}°	96.0587	0.0171	3.9066	0.0000	0.0176			
Δ_{302}°	96.3960	0.0636	3.5222	0.0001	0.0181			
Δ_{786}°	95.0714	0.0393	4.8466	0.0002	0.0425			
Δ_{762}°	95.0167	0.0369	4.9052	0.0005	0.0407			
Δ_{417}°	95.0745	0.0433	4.8389	0.0003	0.0429		0.0001	
Δ_{838}°	94.9092	0.0215	5.0216	0.0000	0.0477			
Δ_{782}°	94.9019	0.0161	5.0359	0.0000	0.0461			
$\Delta_{377}^\circ, \Delta_{499}^\circ, \Delta_{503}^\circ$	93.6500	0.0347	6.2312	0.0005	0.0836			
Δ_{1348}°	93.7075	0.0112	6.1978	0.0001	0.0833		0.0001	
$\Delta_{882}^\circ, \Delta_{856}^\circ$	93.6546	0.0425	6.2190	0.0009	0.0825		0.0005	
Δ_{1340}°	92.2989	0.0064	7.5515	0.0001	0.1427		0.0004	
Δ_{1879}°	92.3015	0.0108	7.5447	0.0002	0.1421		0.0007	
Δ_{1384}°	90.8524	0.0031	8.9219	0.0001	0.2213		0.0012	

Example 2: 2nd roots of a line bundle

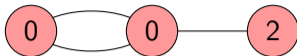

Example 2: 2nd roots of a line bundle

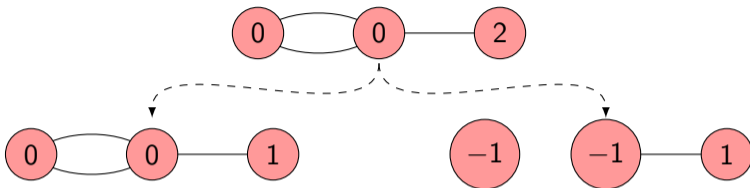

Example 2: 2nd roots of a line bundle

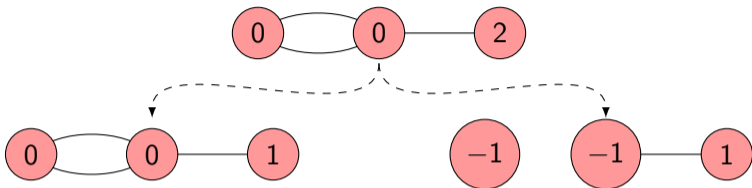

$$h^0 \left(\begin{array}{c} \text{0} \\ \text{0} \\ \text{1} \end{array} \right)$$

Example 2: 2nd roots of a line bundle

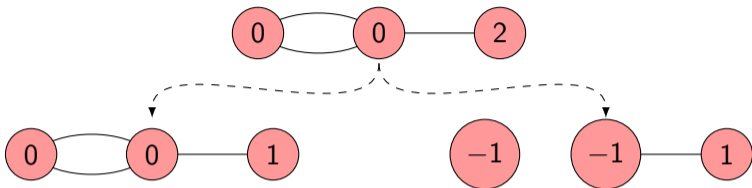

$$h^0 \left(\begin{array}{c} \text{0} \\ \text{0} \\ \text{1} \end{array} \right) \stackrel{T1}{=} h^0 \left(\begin{array}{c} \text{0} \\ \text{0} \end{array} \right) + 1$$

T1: Prune a leaf.

Example 2: 2nd roots of a line bundle

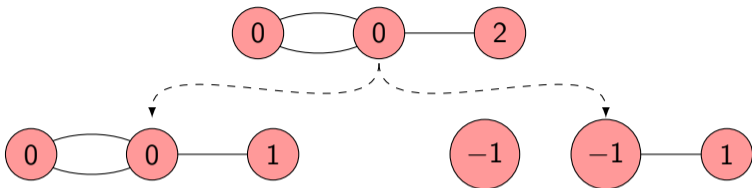

$$h^0 \left(\begin{array}{c} \text{0} \\ \text{0} \\ \text{1} \end{array} \right) \stackrel{T1}{=} h^0 \left(\begin{array}{c} \text{0} \\ \text{0} \end{array} \right) + 1 \stackrel{T2}{=} h^0 \left(\begin{array}{c} \text{0} \end{array} \right) + 1$$

$T1$: Prune a leaf. $T2$: Remove an interior edge.

Example 2: 2nd roots of a line bundle

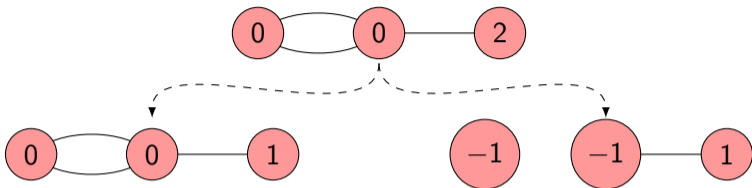

$$h^0 \left(\begin{array}{c} \text{0} \\ \text{0} \\ \text{1} \end{array} \right) \stackrel{T1}{=} h^0 \left(\begin{array}{c} \text{0} \\ \text{0} \end{array} \right) + 1 \stackrel{T2}{=} h^0 \left(\begin{array}{c} \text{0} \end{array} \right) + 1 \geq 1,$$

$T1$: Prune a leaf. $T2$: Remove an interior edge.

Example 2: 2nd roots of a line bundle

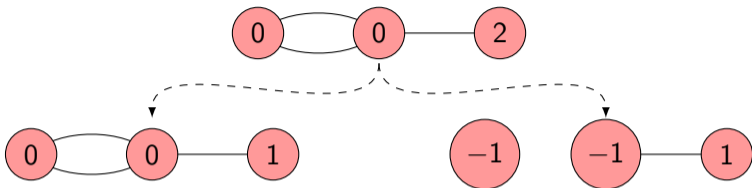

$$h^0 \left(\begin{array}{c} \text{0} \\ \text{0} \\ \text{1} \end{array} \right) \stackrel{T1}{=} h^0 \left(\begin{array}{c} \text{0} \\ \text{0} \end{array} \right) + 1 \stackrel{T2}{=} h^0 \left(\begin{array}{c} \text{0} \end{array} \right) + 1 \geq 1,$$

$$h^0 \left(\begin{array}{c} \text{-1} \\ \text{-1} \\ \text{1} \end{array} \right)$$

$T1$: Prune a leaf. $T2$: Remove an interior edge.

Example 2: 2nd roots of a line bundle

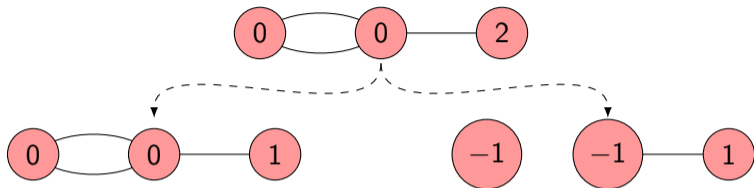

$$h^0 \left(\begin{array}{c} \text{0} \\ \text{0} \\ \text{1} \end{array} \right) \stackrel{T1}{=} h^0 \left(\begin{array}{c} \text{0} \\ \text{0} \end{array} \right) + 1 \stackrel{T2}{=} h^0 \left(\begin{array}{c} \text{0} \end{array} \right) + 1 \geq 1,$$

$$h^0 \left(\begin{array}{c} \text{-1} \\ \text{-1} \\ \text{1} \end{array} \right) \stackrel{T1}{=} h^0 \left(\begin{array}{c} \text{-1} \\ \text{-1} \end{array} \right) + 1$$

$T1$: Prune a leaf. $T2$: Remove an interior edge.

Example 2: 2nd roots of a line bundle

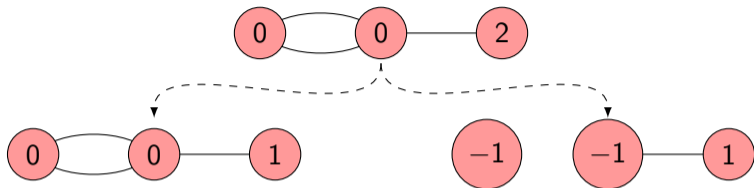

$$h^0 \left(\begin{array}{c} \text{0} \\ \text{0} \\ \text{1} \end{array} \right) \stackrel{T1}{=} h^0 \left(\begin{array}{c} \text{0} \\ \text{0} \end{array} \right) + 1 \stackrel{T2}{=} h^0 \left(\begin{array}{c} \text{0} \end{array} \right) + 1 \geq 1,$$

$$h^0 \left(\begin{array}{c} \text{-1} \\ \text{-1} \\ \text{1} \end{array} \right) \stackrel{T1}{=} h^0 \left(\begin{array}{c} \text{-1} \\ \text{-1} \end{array} \right) + 1 = 1.$$

$T1$: Prune a leaf. $T2$: Remove an interior edge.

Example 2: 2nd roots of a line bundle

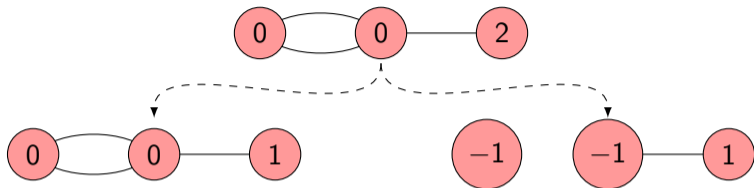

$$h^0 \left(\begin{array}{c} \text{0} \\ \text{0} \\ \text{1} \end{array} \right) \stackrel{T1}{=} h^0 \left(\begin{array}{c} \text{0} \\ \text{0} \end{array} \right) + 1 \stackrel{T2}{=} h^0 \left(\begin{array}{c} \text{0} \\ \text{0} \end{array} \right) + 1 \geq 1,$$

$$h^0 \left(\begin{array}{c} \text{-1} \\ \text{-1} \\ \text{1} \end{array} \right) \stackrel{T1}{=} h^0 \left(\begin{array}{c} \text{-1} \\ \text{-1} \end{array} \right) + 1 = 1.$$

$T1$: Prune a leaf. $T2$: Remove an interior edge.

Classification of rational circuits up to $\beta_1 = 3$

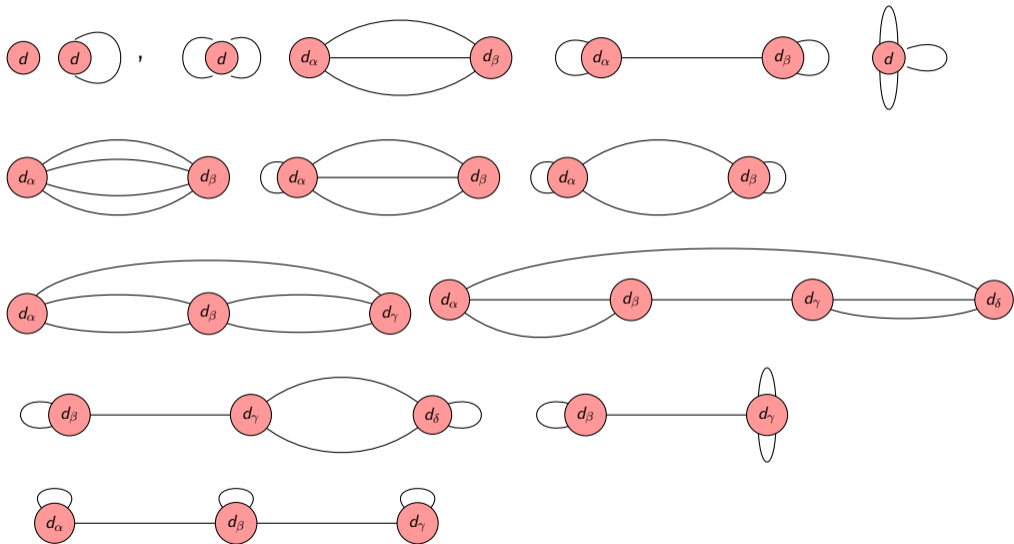

Summary and outlook

- Summary:
 - Pushed ability to tell h^0 for limit roots to the next level.
 - More than 93.91% of configs. of 33 QSM families have no exotics in rep. $(\bar{\mathbf{3}}, \mathbf{2})_{1/6}$.

Summary and outlook

- Summary:
 - Pushed ability to tell h^0 for limit roots to the next level.
 - More than 93.91% of configs. of 33 QSM families have no exotics in rep. $(\bar{\mathbf{3}}, \mathbf{2})_{1/6}$.
- Outlook:
 - Physics advances:
 - Which spin bundles \mathcal{S} on the matter curves are compatible with the compactification?
 - Which \mathcal{F}_R are induced from G_4 -flux in F-theory QSMs?
 - Understand the smoothing $C_R^\bullet \rightarrow C_R$ from Yukawa interactions?

Summary and outlook

- Summary:
 - Pushed ability to tell h^0 for limit roots to the next level.
 - More than 93.91% of configs. of 33 QSM families have no exotics in rep. $(\bar{\mathbf{3}}, \mathbf{2})_{1/6}$.
- Outlook:
 - Physics advances:
 - Which spin bundles \mathcal{S} on the matter curves are compatible with the compactification?
 - Which \mathcal{F}_R are induced from G_4 -flux in F-theory QSMs?
 - Understand the smoothing $C_R^\bullet \rightarrow C_R$ from Yukawa interactions?
 - Mathematics advances:
 - Formulate Brill-Noether theory of (limit) roots on nodal curves.
 \leftrightarrow Gain inspiration from machine learning techniques?
 - Applications in cryptography?

Summary and outlook

- Summary:
 - Pushed ability to tell h^0 for limit roots to the next level.
 - More than 93.91% of configs. of 33 QSM families have no exotics in rep. $(\bar{\mathbf{3}}, \mathbf{2})_{1/6}$.
- Outlook:
 - Physics advances:
 - Which spin bundles \mathcal{S} on the matter curves are compatible with the compactification?
 - Which \mathcal{F}_R are induced from G_4 -flux in F-theory QSMs?
 - Understand the smoothing $C_R^\bullet \rightarrow C_R$ from Yukawa interactions?
 - Mathematics advances:
 - Formulate Brill-Noether theory of (limit) roots on nodal curves.
 \leftrightarrow Gain inspiration from machine learning techniques?
 - Applications in cryptography?
 - Software advances:
 - Speedups to make computations feasible for roots on Higgs curve.
 - Integrate root counter into [FTheoryTools](#) (cf. talk by Andrew Turner).

Summary and outlook

- Summary:
 - Pushed ability to tell h^0 for limit roots to the next level.
 - More than 93.91% of configs. of 33 QSM families have no exotics in rep. $(\bar{3}, 2)_{1/6}$.
- Outlook:
 - Physics advances:
 - Which spin bundles \mathcal{S} on the matter curves are compatible with the compactification?
 - Which \mathcal{F}_R are induced from G_4 -flux in F-theory QSMs?
 - Understand the smoothing $C_R^\bullet \rightarrow C_R$ from Yukawa interactions?
 - Mathematics advances:
 - Formulate Brill-Noether theory of (limit) roots on nodal curves.
 \leftrightarrow Gain inspiration from machine learning techniques?
 - Applications in cryptography?
 - Software advances:
 - Speedups to make computations feasible for roots on Higgs curve.
 - Integrate root counter into [FTheoryTools](#) (cf. talk by Andrew Turner).



Thank you for your attention!

Example: Spin bundles on nodal curve



Example: Spin bundles on nodal curve



Example: Spin bundles on nodal curve

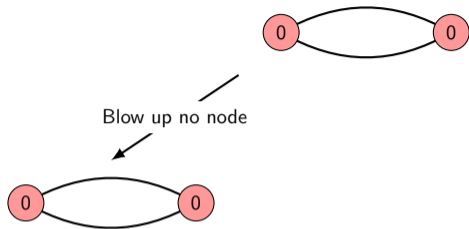

Example: Spin bundles on nodal curve

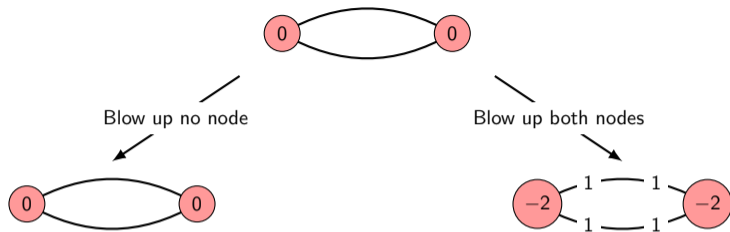

Example: Spin bundles on nodal curve

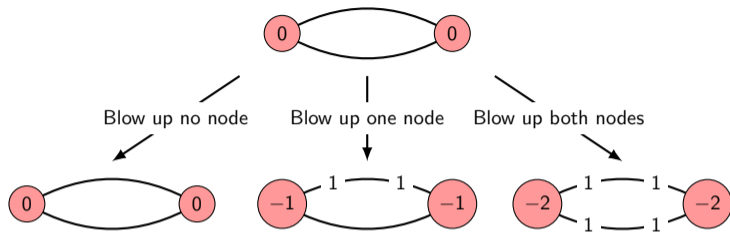

Example: Spin bundles on nodal curve

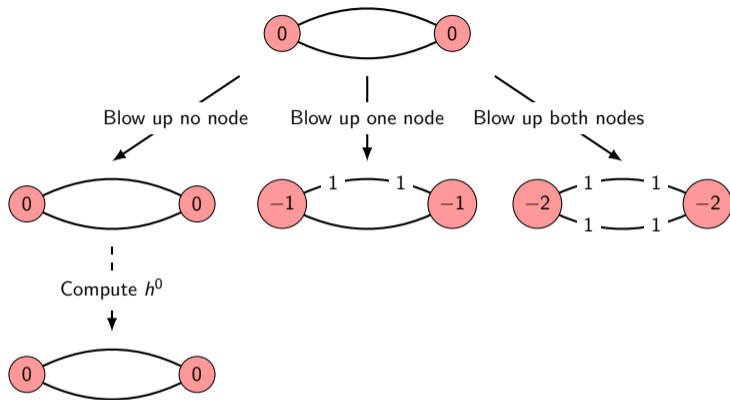

Example: Spin bundles on nodal curve

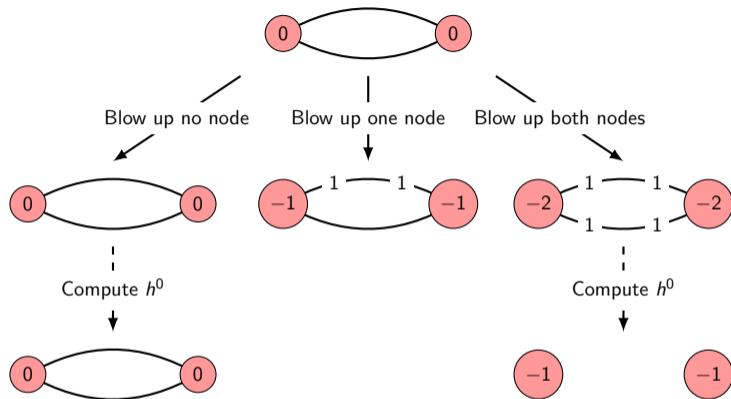

Example: Spin bundles on nodal curve

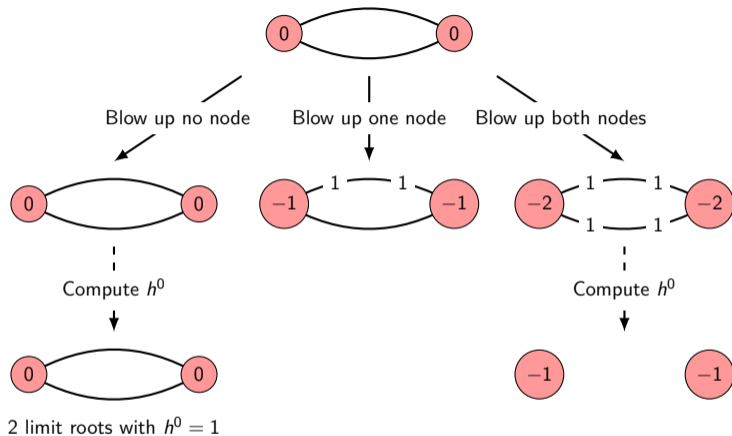

Example: Spin bundles on nodal curve

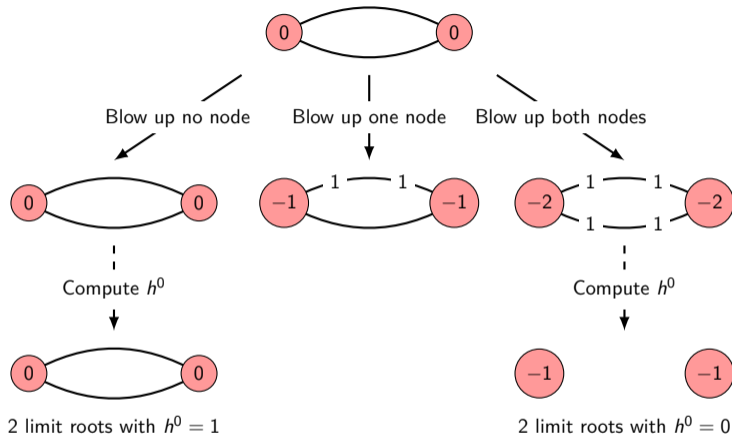

Example: Spin bundles on nodal curve

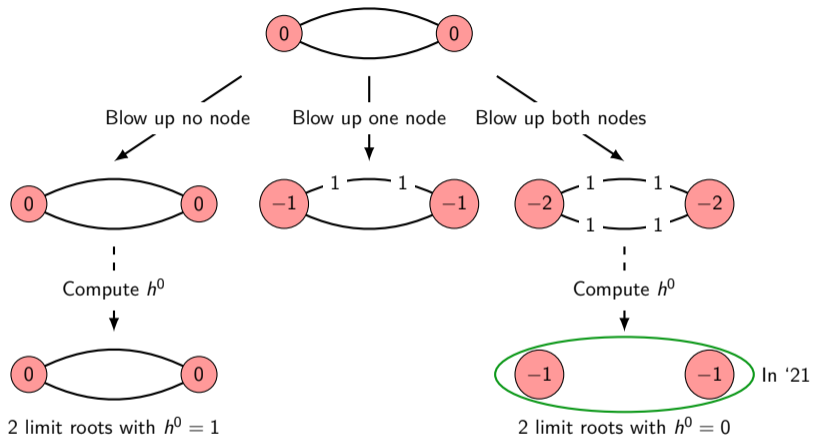

Example: Spin bundles on nodal curve

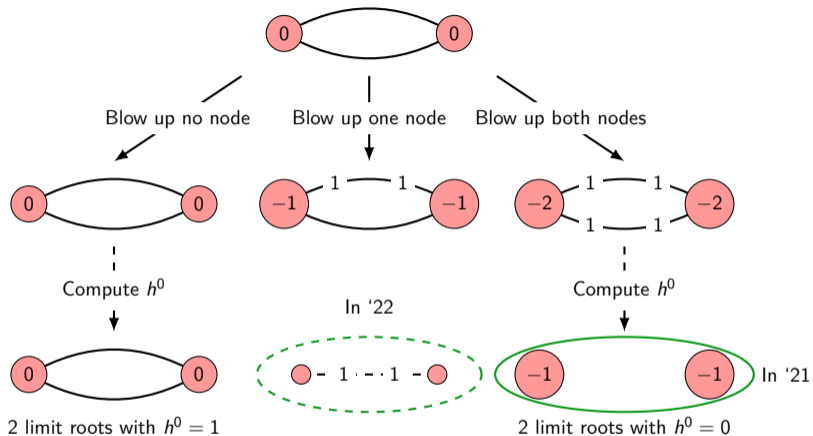

Example: Spin bundles on nodal curve

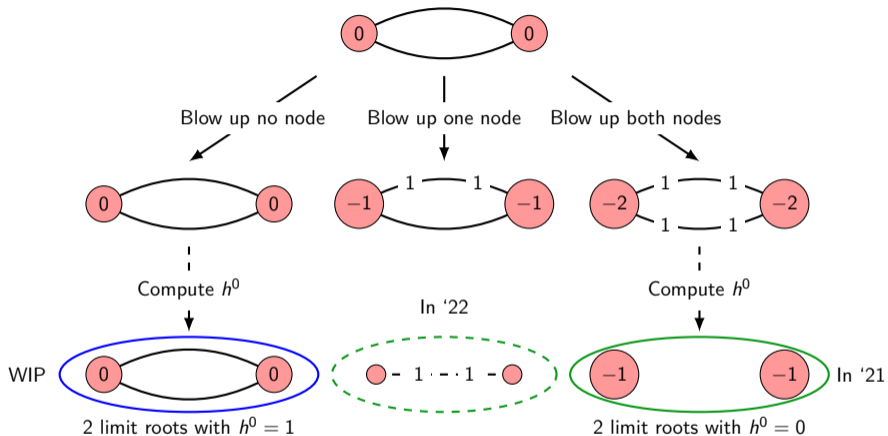

Example: Spin bundles on nodal curve

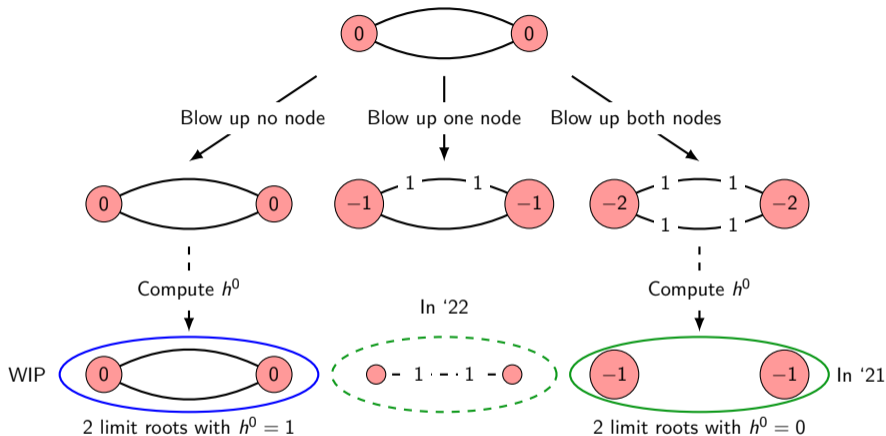

Smooth, irreducible curve

Nodal curve

$h^0 = 0$ $h^0 \geq 0$ $h^0 = 1$ $h^0 \geq 1$

2

2

Example: Spin bundles on nodal curve

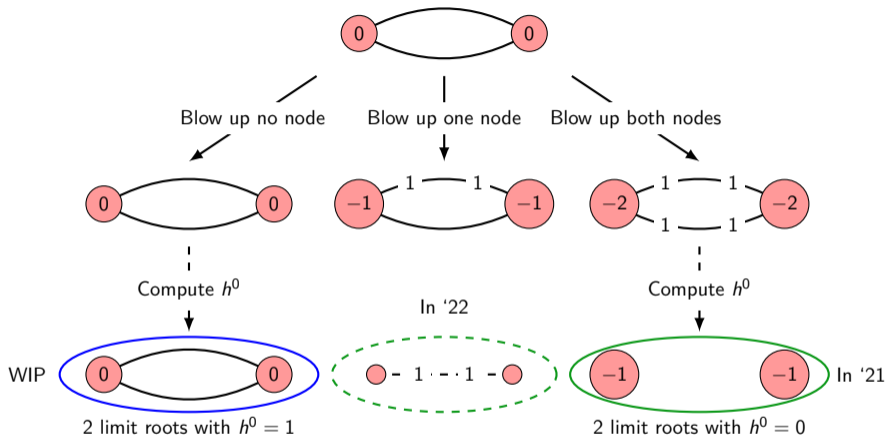

Smooth, irreducible curve				Nodal curve			
$h^0 = 0$	$h^0 \geq 0$	$h^0 = 1$	$h^0 \geq 1$	$h^0 = 0$	$h^0 \geq 0$	$h^0 = 1$	$h^0 \geq 1$
3		1		2		2	

- ① First estimates computed in [M.B. Cvetič Liu '21]:
 - Enumerate **full blow-up** limit roots with $h^0 = 3$.
 - No estimate for uncertainties.

- 1 First estimates computed in [M.B. Cvetič Liu '21]:
 - Enumerate **full blow-up** limit roots with $h^0 = 3$.
 - No estimate for uncertainties.
- 2 Refinement/extension in [M.B. Cvetič Donagi Ong '22]:
 - Enumerate **all** limit roots.
 - h^0 -computation from line bundle cohomology on rational **tree-like** nodal curves.

- ① First estimates computed in [M.B. Cvetič Liu '21]:
 - Enumerate **full blow-up** limit roots with $h^0 = 3$.
 - No estimate for uncertainties.
 - ② Refinement/extension in [M.B. Cvetič Donagi Ong '22]:
 - Enumerate **all** limit roots.
 - h^0 -computation from line bundle cohomology on rational **tree-like** nodal curves.
 - ③ Yet more refinements [M.B. Cvetič Donagi Ong '23 **WIP**]:
 - h^0 -computation on rational and elliptic **circuits**.
 - Achieved by 3-step procedure:
 - ① Prune trees,
 - ② Remove internal edges,
 - ③ Classification of terminal circuits and their line bundle cohomologies.
- ⇒ Optimal results: Refinements require geometric data that is currently not available.
(Required refined data: Descent data of line bundles, divisor on elliptic components.)